

SCR

Solid carbide reamers
According to works standard
Left hand spiral
Right hand cut
Tolerance H7

SCR

Vollhartmetall Reibahlen
Nach Werksnorm
Linksspirale
Rechtsschneidend
Toleranz H7

SCR

Alésoirs en carbure
Selon norme d'usine
Hélice à gauche
Coupe à droite
Tolérance H7

GRP
E11

FAM
320

SC1000
K10

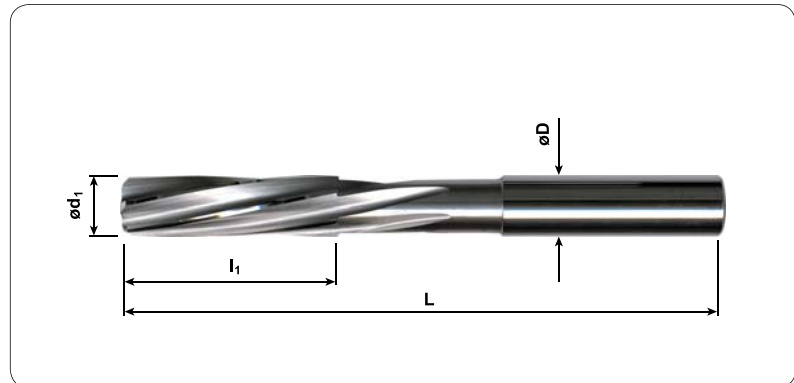

P1 P2 P3 P4 P6 M1 M2 K1 K2 N1 N2 N4 N5

Item Nr.	Designation	ød ₁ H7	l ₁	L	øD	Z
15.11.1027	SCR-LH 0200 SC1000	2,0	12	40	2,0	4
15.11.1028	SCR-LH 0250 SC1000	2,5	12	40	2,5	4
15.11.1029	SCR-LH 0300 SC1000	3,0	12	50	3,0	4
15.11.1030	SCR-LH 0350 SC1000	3,5	15	52	3,5	4
15.11.1031	SCR-LH 0400 SC1000	4,0	18	55	4,0	4
15.11.1032	SCR-LH 0450 SC1000	4,5	20	58	4,5	4
15.11.1033	SCR-LH 0500 SC1000	5,0	22	62	5,0	4
15.11.1034	SCR-LH 0550 SC1000	5,5	22	62	5,5	4
15.11.1035	SCR-LH 0600 SC1000	6,0	25	66	6,0	6
15.11.1036	SCR-LH 0650 SC1000	6,5	25	66	6,5	6
15.11.1037	SCR-LH 0700 SC1000	7,0	25	75	7,0	6
15.11.1038	SCR-LH 0800 SC1000	8,0	28	79	8,0	6
15.11.1039	SCR-LH 0900 SC1000	9,0	35	100	9,0	6
15.11.1040	SCR-LH 1000 SC1000	10,0	35	100	10,0	6
15.11.1041	SCR-LH 1100 SC1000	11,0	35	100	11,0	6
15.11.1042	SCR-LH 1200 SC1000	12,0	35	100	12,0	6

Ordering example :

2 pcs SCR-LH 1000 SC1000 (Item number 15.11.1040)

SCR 8089

Solid carbide reamers
According to DIN8089
Left hand spiral
Right hand cut
Odd indexing
Tolerance H7

SCR 8089

Vollhartmetall Reibahlen
Nach DIN8089,
Linksspirale
Rechtsschneidend
Ungleiche Teilung
Toleranz H7

SCR 8089

Alésoirs en carbure
Selon DIN8089
Hélice à gauche
Coupe à droite
Denture différente
Tolérance H7

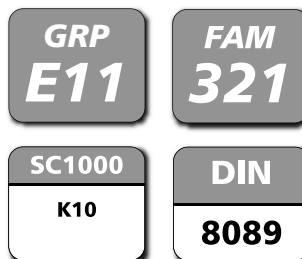
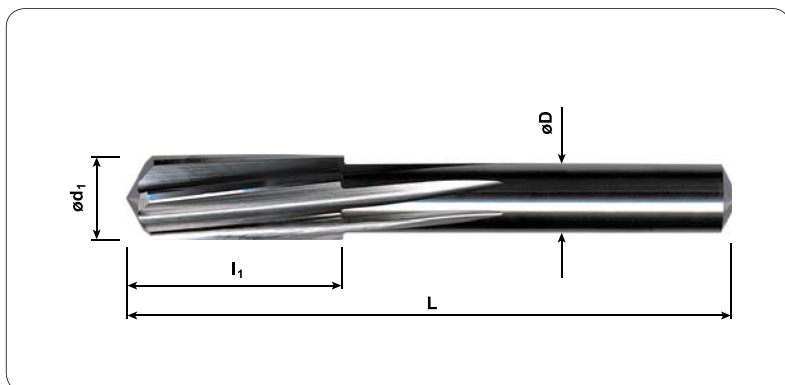

P1 P2 P3 P4 P6 M1 M2 K1 K2 N1 N2 N4 N5

Item Nr.	Designation	$\varnothing d_1$ H7	I_1	L	$\varnothing D$	Z
15.11.1075	SCR-LH 8089 0300 SC1000	3,0	16	50	2,5	4
15.11.1076	SCR-LH 8089 0350 SC1000	3,5	16	50	3,0	4
15.11.1077	SCR-LH 8089 0400 SC1000	4,0	20	50	3,5	4
15.11.1078	SCR-LH 8089 0450 SC1000	4,5	22	63	4,0	4
15.11.1079	SCR-LH 8089 0500 SC1000	5,0	22	63	4,0	6
15.11.1080	SCR-LH 8089 0550 SC1000	5,5	22	63	5,0	6
15.11.1081	SCR-LH 8089 0600 SC1000	6,0	22	63	5,0	6
15.11.1082	SCR-LH 8089 0650 SC1000	6,5	22	63	5,0	6
15.11.1083	SCR-LH 8089 0700 SC1000	7,0	25	71	6,3	6
15.11.1084	SCR-LH 8089 0800 SC1000	8,0	25	71	6,3	6
15.11.1085	SCR-LH 8089 0900 SC1000	9,0	25	71	8,0	6
15.11.1086	SCR-LH 8089 1000 SC1000	10,0	25	71	8,0	6
15.11.1087	SCR-LH 8089 1100 SC1000	11,0	28	80	10,0	6
15.11.1088	SCR-LH 8089 1200 SC1000	12,0	28	80	10,0	6
15.11.1089	SCR-LH 8089 1300 SC1000	13,0	28	80	10,0	6
15.11.1090	SCR-LH 8089 1400 SC1000	14,0	32	90	12,5	6
15.11.1091	SCR-LH 8089 1500 SC1000	15,0	32	90	12,5	6
15.11.1092	SCR-LH 8089 1600 SC1000	16,0	32	90	12,5	6

Ordering example :

2 pcs SCR-LH 8089 1000 SC1000 (Item number 15.11.1086)

R350
Solid carbide reamers
Left hand spiral
Right hand cut
In increments of 1/100mm

R350
Vollhartmetall Reibahlen
Linksspirale
Rechtsschneidend
Um 1/100mm steigend

R350
Alésoirs en carbure
Hélice à gauche
Coupe à droite
Par 1/100mm en hausse

GRP
E11

FAM
322

SC1000
K10

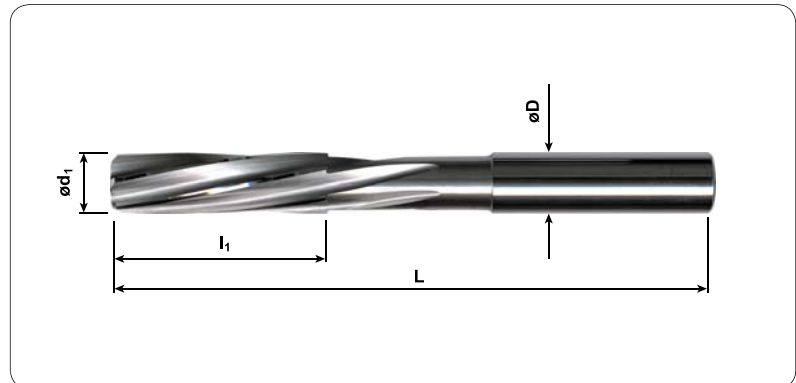

P1 P2 P3 P4 M1 M2 K1 K2 N1 N2 N4 N5

Item Nr.	Designation	ød ₁ H7	l ₁	L	øD	Z
R350	0,60-0,69 SC1000	0,60-0,69	7	33		4
R350	0,70-0,79 SC1000	0,70-0,79	7	33		4
R350	0,80-0,96 SC1000	0,80-0,96	7	33		4
R350	0,97-1,00 SC1000	0,97-1,00	9	38		4
R350	1,01-1,29 SC1000	1,01-1,29	10	38		4
R350	1,30-1,49 SC1000	1,30-1,49	10	38		4
R350	1,50-2,00 SC1000	1,50-2,00	10	50		4
R350	2,01-2,49 SC1000	2,01-2,49	12	50		4
R350	2,50-3,00 SC1000	2,50-3,00	15	70		6
R350	3,01-3,50 SC1000	3,01-3,50	18	70		6
R350	3,51-4,00 SC1000	3,51-4,00	20	70		6
R350	4,01-4,50 SC1000	4,01-4,50	20	70		6
R350	4,51-5,00 SC1000	4,51-5,00	20	70		6
R350	5,01-5,50 SC1000	5,01-5,50	22	75		6
R350	5,51-6,00 SC1000	5,51-6,00	25	75		6
R350	6,01-6,50 SC1000	6,01-6,50	25	75		6
R350	6,51-7,00 SC1000	6,51-7,00	25	75		6
R350	7,01-7,50 SC1000	7,01-7,50	30	85		6
R350	7,51-8,00 SC1000	7,51-8,00	30	85		6
R350	8,01-8,50 SC1000	8,01-8,50	30	85		6
R350	8,51-9,00 SC1000	8,51-9,00	30	100		6
R350	9,01-9,50 SC1000	9,01-9,50	30	100		6
R350	9,51-10,00 SC1000	9,51-10,00	30	100		6
R350	10,01-11,00 SC1000	10,01-11,00	30	100		6
R350	11,01-12,00 SC1000	11,01-12,00	30	100		6
R350	12,01-13,05 SC1000	12,01-13,05	35	100		6

Ordering example :

2 pcs R350 7,51 H6 SC1000
2 pcs R350 6,00 P6 SC1000
2 pcs R350 3,50 SC1000

(non existing item numbers are created when ordered, please see our website for more information)

*) With these reamers available in increments of 1/100mm, all ISO tolerances can be covered /
Mit diesen Reibahlen verfügbahr in Abstufungen von je 1/100mm, können alle ISO Toleranzen abgedeckt werden /
Avec cettes alésoirs disponible en gradation de 1/100 mm, on peut faire tous les tolérances ISO

*) Tolerances / Toleranzen / Tolérances
ø0,60 - ø3,00mm +0 / +0,003mm
ø3,01 - ø6,00mm +0 / +0,004mm
ø6,01 - ø13,05mm +0 / +0,005mm